

0.8t/1.2t/1.6t Mast specification

Type	Fork lift height h ₃	Max. fork height (h ₃ +h ₁₃)	Mast lowered h ₁	Mast extended h ₄	Free lift	Capacity load capacity at 500mm		
						0.8t	1.2t	1.6t
						kg	kg	kg
Wide view mast	2000	2035	1542	2542	0	800	1200	1600
	2500	2535	1792	3042	0	800	1200	1600
	2700	2735	1892	3242	0	800	1200	1600
	3000	3035	2042	3542	0	800	1200	1600
	3300	3335	2192	3842	0	800	1200	1600
	3500	3535	2292	4042	0	800	1200	1600
	3600	3635	2342	4142	0	700	1200	1600
	3700	3735	2392	4242	0	680	1180	1540
	3800	3835	2442	4342	0	660	1150	1480
	4000	4035	2642	4642	0	620	1100	1400
	4300	4335	2792	4942	0	530	1050	1340
	4500	4535	2892	5142	0	440	1000	1300
Wide view full free duplex mast	2000	2035	1595	2595	1035	800	1200	1600
	2500	2535	1845	3095	1285	800	1200	1600
	2700	2735	1945	3295	1385	800	1200	1600
	3000	3035	2095	3595	1535	800	1200	1600
	3300	3335	2245	3895	1685	800	1200	1600
	3500	3535	2345	4095	1785	800	1200	1600
	3600	3635	2395	4195	1835	700	1200	1600
	3700	3735	2445	4245	1885	800	1200	1600
	3800	3835	2495	4295	1935	680	1180	1540
	4000	4035	2695	4495	2135	620	1100	1400
	4300	4335	2795	4695	2235	530	1050	1340
	4500	4535	2895	4795	2335	440	1000	1300
Wide view full free triplex mast	2000	2035	1844	2844	1165	800	1200	1600
	2500	2535	1909	2909	1235	680	1180	1540
	2700	2735	1945	2945	1275	620	1100	1400
	3000	3035	2109	3109	1435	530	1050	1340
	3300	3335	2159	3159	1485	440	1000	1300
	3500	3535	2259	3259	1585	380	950	1220
	3700	3735	2354	3354	1685	300	800	1000
	3800	3835	2409	3409	1735	-	680	850
	4000	4035	2509	3509	1835	-	550	700

2.0t Mast specification

Type	Fork lift height h ₃	Max. fork height (h ₃ +h ₁₃)	Mast lowered h ₁	Mast extended h ₄	Free lift	Capacity load capacity at 500mm
						2.0t
						kg
Wide view mast	2000	2045	1647	2647	0	2000
	2500	2545	1897	3147	0	2000
	2700	2745	1997	3347	0	2000
	3000	3045	2147	3647	0	2000
	3300	3345	2297	3947	0	2000
	3500	3545	2397	4147	0	2000
	3600	3645	2447	4247	0	1950
	3700	3745	2497	4347	0	1900
	3800	3845	2547	4447	0	1840
	4000	4045	2747	4747	0	1800
	4300	4345	2897	5047	0	1680
	4500	4545	2997	5247	0	1600
Wide view full free duplex mast	2000	2045	1700	2700	1045	2000
	2500	2545	1950	3200	1295	2000
	2700	2745	2050	3400	1395	2000
	3000	3045	2200	3700	1545	2000
	3300	3345	2350	4000	1695	2000
	3500	3545	2450	4200	1795	2000
	3600	3645	2500	4300	1845	1950
	3700	3745	2509	4309	1845	1900
	3800	3845	2519	4319	1845	1800
	4000	4045	2709	4509	2035	1745
	4300	4345	2809	4609	2135	1680
	4500	4545	2859	4659	2185	1600
Wide view full free triplex mast	2000	2045	2350	3350	1300	2000
	2500	2545	2400	3400	1350	2000
	2700	2745	2450	3450	1400	2000
	3000	3045	2500	3500	1450	2000
	3300	3345	2550	3550	1500	2000
	3500	3545	2600	3600	1550	2000
	3600	3645	2650	3650	1600	1950
	3700	3745	2659	3659	1600	1900
	3800	3845	2669	3669	1600	1800
	4000	4045	2809	3809	1745	1680
	4300	4345	2909	3909	1845	1600
	4500	4545	2959	3959	1895	1500

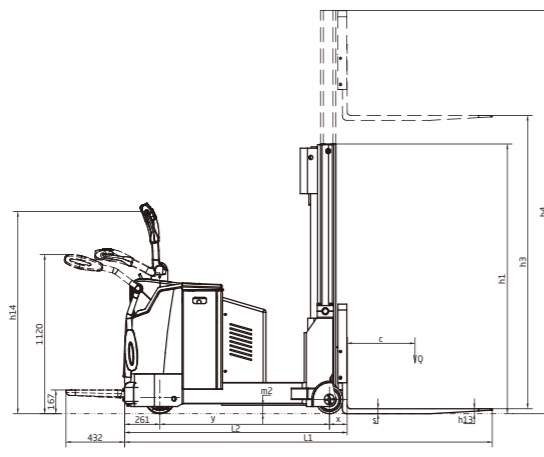
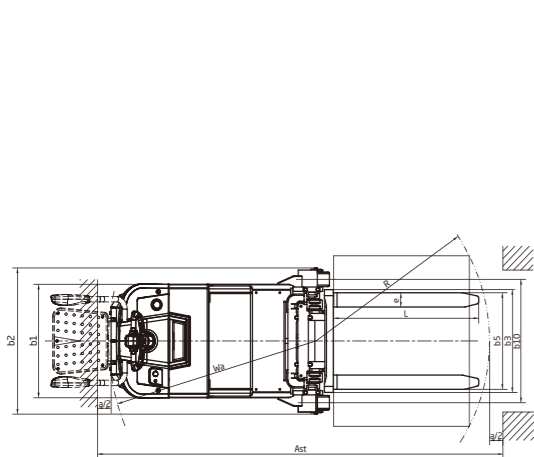

A Series Electric counterbalanced stacker

Distinguishing marks	1.1	HANGCHA GROUP CO.,LTD.				
	1.2	CPDB08-AC15 CPDB08-AZ35	CPDB12-AC15 CPDB12-AZ35	CPDB16-AC15 CPDB16-AZ35	CPDB20-AC15 CPDB20-AZ35	
1.3	Drive:electric(battery or mains),diesel,petrol, fuel gas	electric	electric	electric	electric	
1.4	Operator type:hand,pedestrian,standing,seated,order-picker	standing	standing	standing	standing	
1.5	Rated capacity/rated load	Q (t)	0.8	1.2	1.6	2.0
1.6	Load centre distance	c(mm)	500	500	500	500
1.8	Load distance, centre of drive axle to fork	x(mm)	131	131	141	151
1.9	Wheelbase	y(mm)	1023	1150	1371	1571
2.1	Service Weight incl.battery(see line6.5)	kg	1800	2030	2240	2316
2.2	Axle loading,laden front/rear	kg	420/2180	310/2840	450/3200	531/3595
2.3	Axle loading,unladen front/rear	kg	935/865	1090/860	1150/900	1189/937
3.1	Tyres:solid rubber,superelastic,pneumatic,polyurethane	PU	PU	PU	PU	PU
3.2	Tyre size, front	mm	φ230×75	φ230×75	φ250×100	φ250×100
3.3	Tyre size, rear	mm	φ200×100	φ200×100	φ200×100	φ200×100
3.5	Wheels, number front / rear (x = driven wheels)		1×/2	1×/2	1×/2	1×/2
3.6	Tread, front	b ₁₀ (mm)	870	870	870	870
4.2	Height,mast lowered	h ₁ (mm)	1900	1900	1900	1900
4.4	Lift	h ₃ (mm)	2700	2700	2700	2700
4.9	Height of tiller in drive position min./max.	h ₁₄ (mm)	1115/1420	1115/1420	1115/1420	1115/1420
4.15	Height, lowered	h ₁₃ (mm)	35	35	35	45
4.19	Overall length	l ₁ (mm)	2485 ¹⁾	2612 ¹⁾	2822 ¹⁾	3032 ¹⁾
4.20	Length to face of forks	l ₂ (mm)	1415 ¹⁾	1542 ¹⁾	1752 ¹⁾	1962 ¹⁾
4.21	Overall width	b ₁ /b ₂ (mm)	800/1030	800/1030	800/1030	800/1030
4.22	Fork dimensions	s/e/l (mm)	35/100/1070	35/100/1070	35/100/1070	45/100/1070
4.24	Fork-carriage width	b ₃ (mm)	700	700	700	700
4.25	Distance between fork-arms	b ₅ (mm)	210-680	210-680	210-680	210-680
4.32	Ground clearance, centre of wheelbase	m ₂ (mm)	60	60	60	60
4.34.1	Aisle width for pallets 1000 x 1200 crossways	Ast (mm)	2760 ¹⁾	2810 ¹⁾	3019 ¹⁾	3228 ¹⁾
4.34.2	Aisle width for pallets 800 x 1200 lengthways	Ast (mm)	2870 ¹⁾	2920 ¹⁾	3129 ¹⁾	3339 ¹⁾
4.35	Turning radius	Wa (mm)	1380	1430	1630	1830
5.1	Travel speed, laden/unladen	km/h	5.5/6.0	5.5/6.0	5.5/6.0	5.5/6.0
5.2	Lift speed, laden/unladen	m/s	0.160/0.235	0.145/0.220	0.135/0.230	0.110/0.180
5.3	Lowering speed, laden/unladen	m/s	0.200/0.200	0.200/0.200	0.200/0.200	0.200/0.200
5.7	Gradeability, laden/unladen	%	6/10	6/10	6/10	6/10
6.1	Drive motor rating S2 60 min.	kW	1.5	1.5	3	3
6.2	Lift motor rating at S3 15%	kW	2.2	3.2	3.2	3.2
6.4	Battery voltage/nominal capacity K5	(V)/(Ah)	24/240	24/280	24/350	24/350
6.5	Battery weight	kg	215	250	300	300
8.1	Type of drive control		CURTIS ZAPI	CURTIS ZAPI	CURTIS ZAPI	CURTIS ZAPI

Note:1.)Triplex mast +21mm

Specifications are subject to change without notice.



HANGCHA

Hangcha Europe GmbH

Mariechen-Graulich-Straße 12a,
65439 Flörsheim am Main,
Germany

Tel: 0049-61453769188

E-mail: admin@hangchaeurope.com

Mob: 0049-16096548808 (Thomas Dittrich)

E-mail: thomas.dittrich@hangchaeurope.com

Zip Code Area (1,2,3,4,5,6,7)

Mob: 0049-1605272481 (Jens Abmuth)

E-mail: jens.assmuth@hangchaeurope.com

Zip Code Area (0,8,9)

www.hangchaeurope.com



Follow us on
Instagram



Follow us on
Facebook



Follow us on
YouTube



Download "Hangcha
Forklift" App



ISO14001:2015



ISO9001:2015



HANGCHA trucks conform
to the European Safety
Requirements.

HANGCHA GROUP CO.,LTD. reserves the right to make any changes without notice concerning colors, equipment, or specifications detailed in this brochure, or to discontinue individual models. The colors of trucks, delivered may differ slightly from those in brochures.

2018 VERSION 1/COPYRIGHT 2018/12



A Series Electric Counterbalanced Stacker

with capacities of 800 to 2,000kg

The World of Hangcha



HANGCHA

A Series Electric Counterbalanced Stacker

Is widely used in pallet stacking, wherever support arm stacker truck cannot operate close pallet and lower pallet. Applied the latest AC drive technology, advanced performance, comfort, safe, reliable, low maintenance cost, easy to operate, and economical to buy is the ideal solution for warehouses, supermarkets, workshop loading/unloading and handling pallets of cargos.

Environment/ Efficiency/ Economy

Appearance

- / A series electric counterbalanced stacker applied professional industrial design, stream lines, and compact, and fully ergonomic consideration, in line with the latest design trends.
- / Applied steel stamping and injection molding processes for front and back guard, which is robust, durable, and also environmental compliance.



High Performance

- / Electric power steering is standard specification, which provides flexible operation.
- / Pump motor controller offers proportional lifting/lowering, low noise, energy consumption reduced by 15%.
- / Powered by AC traction motor not only has good acceleration and climbing performance, but also low heat, brushless, maintenance-free.
- / Latest AC control system, precise and smooth.
- / CAN-BUS connection enables all truck data can be read out for inspection, and also improves the data transition more quick and reliable.
- / Regenerative braking for battery recovery during travel speed reduction, anti-slope on gradient.
- / All key parts such as switches, connectors, battery indicator and hour meter all adopt the famous brand.

Comfort

- / The pedal applies shock absorption design, greatly improves the operator's comfort, reduce the fatigue.
- / The compact body and semicircular design provide an ideal operation in limited space, and the wedge designed chassis greatly increases the passing ability.

Reliability

- / 3-pivot with low centre of gravity design and high strength steel frame structure chassis provide high residual load capability and longer working life.
- / Imported waterproof connectors, all wires and cables are protected, greatly improve the reliability of the electric system.
- / Using non-contact proximity switch, improves safety and reliability.
- / Hydraulic power unit applied to provide low noise, low vibration, smooth lifting and landing reliable operation.
- / The REMA tiller made in Germany of latest development is simple but beautiful, and all operations can be done easily with one hand.
- / H-type mast profile section is applied to provide stable lifting and high strength.
- / The power plug is fixed on the chassis to avoid damage during battery replacement.

Maintenance

- / AC motor without carbon brushes, maintenance-free, cost saving.
- / Integrated battery indicator, hour meter and self-diagnostic instrument.



Standard Specification

- / AC drive motor
- / Electric power steering
- / 2.7m double cylinder duplex mast
- / Emergency switch
- / The proportional lift & lower control
- / 1070mm fork length
- / Side battery change
- / Multi-function battery indicator
- / PU load wheel
- / CAN bus technology
- / Soft landing system

Options

- / Mast lift height:
Duplex mast 2000-4500mm,
full free duplex mast: 2000-3600mm,
triplex mast 0.8t: 3500-5000mm,
1.2/1.6/2.0t: 3500-5500mm.
- / Mast tilting: Forward 2° Backward 6°
- / Different length of fork
- / Load backrest



Simple and beautiful tiller designed to improve the operator's driving comfort. Optimized designing structure to offer a good visibility and easy entrance to the pallet



Side battery change is standard specification



Fully opened hood, easy accessibility of all components, is easy for service



Mast tilting is the optional feature, offers proportional forward/backward speed

Safety

- / Travel speed will be automatically reduced after fork lifting height over 500mm.
- / Automatic deceleration during turning.
- / Punch-formed handrails provide more safety to the operator.
- / Three braking system of regenerative braking, reverse current braking, and emergency braking, insures the safe operation.
- / Anti-slope on gradient can keep the safety.
- / The emergency button on the tiller head can effectively avoid the harm to the driver.
- / Soft landing system applied to protect loads from damaging when forks lowering to 100mm to ground.